



RAMS-2010 CRIMPER/BEADER

Capacity 24 Ga. Mild Steel Maximum

OPERATION:

Use the crank screw (A) to raise or lower the upper rolls (C) into and away from the item you are forming. Set depth gauge (E) by rotating the knob (F) and tightening down. Use adjusting wheel (D) to obtain fade-away or straight crimp as required. NO TOOLS NEEDED. Once item is set, turn handle (B) and push material into rolls.

*See product video for more information.

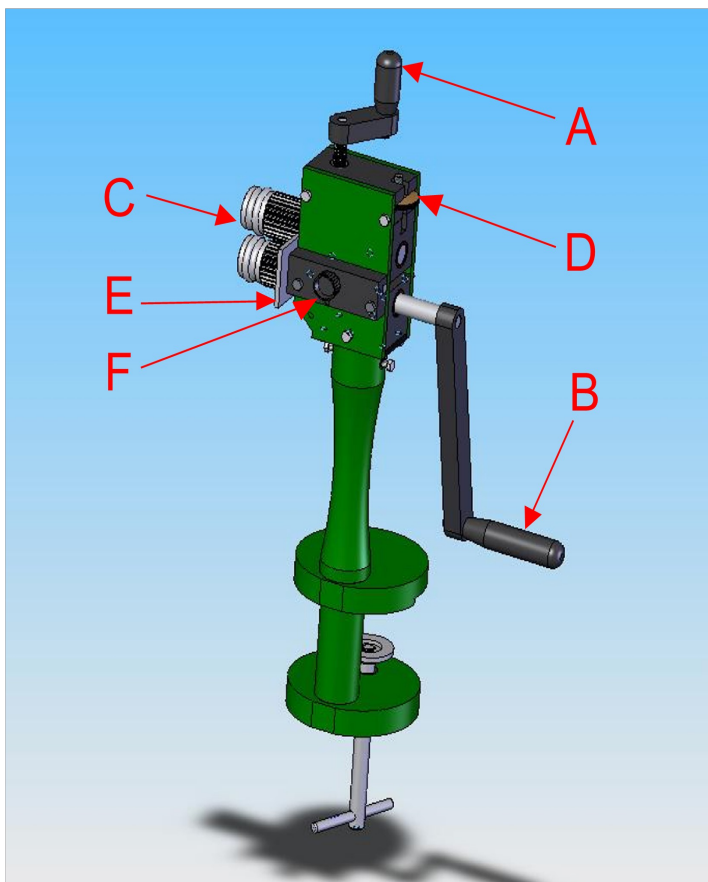

MAINTENANCE:

1. Keep rollers clean and free of galvanized deposits.
2. Occasionally spray rollers with WD-40.

AVAILABLE ROLL SETS:

RAMS 2010-K includes:

Single bead rollers
Burring Rollers
Turning Rollers
Wiring Rollers

RAMS-BD (2-3/4" extended 1/4" bead).

RAMS-OGB (2-1/2" extended OG bead).

FOR REPLACEMENT PARTS:

Please verify part number on our website and then call RAMS Sheet Metal Equipment at 262-925-8920.